

SCALING NEW HEIGHTS



April 18 & 19, 2012

ISA Edmonton 2012 Exhibit & Conference

EXHIBITOR REFERENCE MANUAL

- 1.0 2012 EXHIBIT OVERVIEW
- 2.0 RULES & REGULATIONS
- 3.0 OFFICIAL SHOW CONTRACTORS
- 4.0 ISA EDMONTON 2012 EXHIBIT & CONFERENCE PRIMARY CONTACTS

ADDITIONAL SHOW SERVICES

Available Downloads:

Conexsys – Lead Retrieval Services
R.E. Rogers – Freight and Customs
Showtech – Power, Lighting & Telephone
Superior Show Service – Trade Show Services

Additional Information, Downloads & Forms are available...log in to the [Secure Exhibitor Login](#) using the username & password that was sent to you via email. If you have not received an email with this pertinent information, please contact Dennis Miller at info@isaedmontonshow.ca

PROMOTIONAL MATERIALS

- CLIENT INVITATION TEMPLATE - Download Template
- OFFICIAL EVENT GUIDE ADVERTISING OPPORTUNITIES (See website for rate card and order form)
- COMPLIMENTARY PASS LINKS & BANNERS FOR EMAILS AND WEBSITES

* Downloads are available ...log in to the **Exhibitor Resources** by clicking the [Secure Exhibitor Login](#) at <http://isaedmontonshow.ca/>

1.0 2012 EXHIBIT OVERVIEW

1.1 PROGRAM & SHOW FEATURES

In addition to the Exhibit this event will feature numerous Presentations. Be sure to take advantage of these opportunities to promote your products, educate your staff and ensure your customers are motivated to attend and are supported by their employers. This year's Show features the following:

- **OVER 35,000** square feet of **Exhibits**
- **TUNDRA Rock Wall** – All proceeds to **Kids Cancer Care Foundation** (see website for more information)
- **CONFERENCE** – Details to come
- **OPEN FORUM ON SHOW FLOOR** - Details to come

1.2 BUILDING TRAFFIC TO YOUR BOOTH

“Success is where Preparation meets Opportunity” – Zig Ziglar

A significant part of a successful Trade Show is **“Pre-show” marketing**. Below is a list of available marketing tools designed to help build traffic to your booth...log in to the [Secure Exhibitor Login](#) using the username & password that was sent to you via email. If you have not received an email with this pertinent information, please contact Dennis Miller at info@isaedmontonshow.ca

A. Client Invitation

A Client Invitation template is available for download. Customize the Invitation with your company name, promotional information and booth number. Client Invitations have proven to be an effective and productive method for exhibitors to promote attendance to their individual booths. Proactive exhibitors use the invitations extensively to invite their customers and future prospects to generate booth traffic. It also gives exhibitors the opportunity to promote specific technologies or products that will be on display.

B. ISA Edmonton 2012 Exhibit & Conference Email & Website Banners to insert into all of your emails and create links on your company website.

C. Official Event Guide

ISA Edmonton 2012 Exhibit & Conference Official Event Guide, published by Execu Graphx Inc., is the only publication with exclusive distribution rights at Show Registration. This is the only approved Event Guide.

- Take advantage of the 2 **FREE** Product Showcase features as well as the **highlighted Company Profile**.
- There will be a total of 6,000 Exhibit Guides produced. Approximately 3,000 Guides will be mailed to pre-registered and previous attendees and the remaining 3,000 will be available on the Exhibit Floor.

Rate card and Order form available under the Marketing Materials Menu Tab.

D. Rotating Website Banner Ad

Call Lea-ann at 780-467-6729 for more information.

2.0 RULES & REGULATIONS

2.1 SHOW MANAGEMENT

If there are any questions pertaining to this manual or pertaining to the Show, please contact:

CEM Charlton Event Management

126, 150 Chippewa Road
Sherwood Park, AB T8A 6A2
Canada

Contact: Dennis Miller

Phone: 780.690.2600

Fax: 780.449.3529

Email: info@isaedmontonshow.ca

2.2 VENUE

The ISA Edmonton 2012 Exhibit and Conference will be taking place at the Edmonton Expo Centre in Halls F and G & H.

[Edmonton Expo Centre at Northlands](#)

7515 – 118 Avenue
Edmonton, Alberta T5B 4X4
Canada

2.3 SHOW MOVE-IN SCHEDULE

	<u>Booth Size</u>	<u>Time</u>	
Monday	April 16, 2012	400 sq. ft. +	2:00 p.m. – Midnight
Tuesday	April 17, 2012	100 to 400 sq. ft.	8:00 a.m. – Midnight

DUE TO LIABILITY CONCERNS, ANY PERSON UNDER THE AGE OF 16 IS NOT PERMITTED ON THE SHOW FLOOR DURING MOVE-IN, SHOW DAYS AND MOVE-OUT.

All set-up activity will be restricted to the confines of the booth space after 6:00 p.m. on Tuesday, April 17, 2012, to allow for crate storage, aisle carpet installation, building cleaning and final inspection by Show Management. Dollies and forklifts are not permitted after 6:00 p.m. on Tuesday, April 17, 2012. Exhibitors may access their Booth on Wednesday, April 18 at 8:00 a.m. to set-up literature, etc., but Booth displays and equipment must be installed in the Booth no later than 8:00 p.m. on Tuesday.

ABSOLUTELY NO DOLLIES WILL BE PERMITTED IN THE EXHIBIT AREA, AFTER THE AISLE CARPETS ARE INSTALLED!

2.4 SHOW MOVE-OUT SCHEDULE

HALLS F, G & H

THURSDAY, APRIL 19, 2012 - 5:00 P.M. - MIDNIGHT

Once the Show has closed, all empty crates and boxes will be brought to the Booth as soon as the aisle carpets have been removed. Exhibitors are requested to keep the aisles clear until the aisle carpets have been removed and the crates have been returned to each Exhibitor.

Show Management urges Exhibitors to remove small cartons and open cases of products from the Show area immediately after the close of the Show. While Show Management will take all reasonable security measures to safeguard exhibits, it assumes no responsibility for loss of, damage to, or theft of property of Exhibitors however caused. Immediate removal of small items will minimize the possibility of loss or theft.

Packed crates for outbound shipments must be clearly labeled and left in the Booth for pickup by the official Show Carrier or your selected Freight Carrier.

2.5 SHOW HOURS

Wednesday	April 18, 2012	10 a.m. – 5:00 p.m.
Thursday	April 19, 2012	10 a.m. – 5:00 p.m.

2.6 EXHIBITOR STAFF BADGES

Exhibitor Registration

Tuesday	8:00 a.m. – 6:00 p.m.
Wednesday	8:00 a.m. – 5:00 p.m.
Thursday	8:00 a.m. – 5:00 p.m.

In order to have access to the Show floor, all Exhibitors must be wearing their Badges starting Tuesday, April 17, 2012 from 8:00 a.m. until the Show Move Out is complete on Thursday, April 19, 2012.

To order Staff Badges, please visit the ISA Website and login under the [Secure Exhibitor Login](#) using the username and password that was sent to each Exhibitor via e-mail. If you have not received an e-mail with this pertinent information, please contact Dennis Miller via e-mail at info@isaedmontonshow.ca. ***Exhibitor Staff Badges can be picked up at the Exhibitor Registration Counter during move-in after 8:00 a.m. on Tuesday, April 17, 2012.***

2.7 EXHIBITOR PARKING

Exhibitor parking passes can be purchased at the Expo Centre on Tuesday, April 17 between **9 a.m. – 4 p.m.** during move-in and at the toll booths April 18th **only**. The rate is \$10.00/pass/day and includes in/out privileges. Parking passes are not required for both move-in days. Daily parking passes can be purchased at the toll booths at \$12.00/pass/day, with no in/out privileges.

2.8 SHOW TERMS & CONDITIONS

Character of the Show

All displays must be of a high caliber in keeping with Industrial Trade Show Standards. The ISA Exhibit Committee prior to the Show must approve two tier Booths. Final acceptance of displays on set-up days, from the ISA Exhibit Committee is mandatory.

Payment Terms

To assure participation, Exhibitors must submit a complete Registration Form with a 30% deposit prior to the Exhibit deadline. Deposits are non-refundable. Full payment must be received by January 31, 2012. In the event that the ISA Edmonton 2012 Exhibit and Conference is cancelled for any reason, Show Management will not be liable to the Exhibitor, except to reimburse any funds paid to that date for Exhibit space.

Samples, Souvenirs and Soliciting

Soliciting of business and/or distribution of samples and souvenirs must be confined to Exhibitors own Booth Space. Exhibitor Literature is not permitted outside the confines of said Booth; if found in empty booths, aisles or main Registration areas, your materials will be removed.

Security

Security Guards will be on duty 24 hours a day (on a roaming basis only), from the opening of move-in to the closing of move-out. Show Management will not accept any liability for loss or damage to the Exhibitor's booth or materials. All property of the Exhibitor is understood to remain under the Exhibitor's custody and control, in transit to and from, or within the confines of the Exhibit Hall.

2.9 SERVICES • included in exhibit space cost

The basic 10' x 10' booth includes the following:

- Sidewall drape
- Backwall drape
- All materials handling within Exhibit Halls up to 5,000 lbs., which includes:
 - (2), 3000 lb. forklifts
 - (2), 5000 lb. forklifts
- Daily cleaning of aisle and general area carpet only
- Security services
- Exhibit Registration services
- Two move-in days (schedule will be provided), two Exhibit days, and one move-out day

2.9 SERVICES (continued)

The following are examples of items **NOT** included in the Exhibitor's Package:

- Power connection
- Booth carpeting and underpadding
- Table(s), chair(s), desk(s), counter(s), shelf rentals, etc.
- Parking passes
- Food and beverage service
- Booth cleaning
- Exhibitor signage
- In-booth security
- Liability Show Insurance
- Telephone lines and units
- Booth décor (i.e. plants, etc.)
- Audio visual equipment rentals
- Computer rentals
- Freight services
- Customs Broker services
- Customized booth design
- In-booth forklift work is not included in the cost of Exhibit Space

NOTE:

IF FORKLIFT SERVICES ARE REQUIRED FOR SHIPMENTS OVER 5,000 LBS, A SPECIAL FORKLIFT MUST BE ORDERED WITH SUPERIOR SHOW SERVICES INC. (THIS IS NOT INCLUDED IN THE COST OF YOUR EXHIBIT SPACE).

2.10 BOOTH OPERATIONS

Exhibitors must ensure a fully staffed Booth during Show hours. During Show hours, moving in/out or dismantling will not be permitted and any movement must be approved and arranged by Management. No forklifts or dollies on aisle carpet at any time. Dismantling must not commence until 5:15 p.m., Thursday, April 19, 2012. For the safety of the public, we ask that Exhibitors wait for 15 minutes after the Show closes before beginning to move-out.

Exhibitors will also be expected to keep all displays and equipment within their designated space and not in the aisles. In deference to fellow Exhibitors and to the professional people who comprise the Audience, Exhibitors are specifically prohibited from employing any type of attraction, which in the opinion of the Show Management, detracts from the professional nature of the Show.

2.11 SOUND SYSTEM AND NOISE LEVELS

If you will be demonstrating equipment that causes noise, you must confine your operation to suitable intervals, so that you don't impose on neighbouring Exhibits. Watch your own Booth to be sure the noise level from your demonstration or sound system is kept to a minimum and not interfering with others. **Show Management reserves the right to determine when sound constitutes interference with others and to shut the system down.** Exhibitors who plan to use a promotional game in their Booth must notify Show Management.

2.12 FLOOR COVERING

Show Management attaches the utmost importance to the appearance of the Show. Carpet or suitable flooring is required in your Booth. Carpet may be rented from Superior Show Service, or Exhibitors may bring their own floor covering.

2.13 FLOOR OF BUILDING

The following is **STRICTLY PROHIBITED** by Edmonton Expo Centre:

- Drilling holes in the floor
- Attachment to, painting, or any other defacement of the floor
- Using ramset fasteners or masonry nails to fasten display material to the floor
- Fastening/nailing strips to any of the building walls or floors by any means
- Adhering tile, floor covering, or any other structure directly to the building floor (building paper or other suitable protection must be laid on the floor first)

2.14 GENERAL BOOTH CONFIGURATION INFORMATION

In the following information, you will find regulations outlining Booth construction. Keep in mind that the information provided is a guideline only. This information should be used as a gauge when determining the configuration of your Booth. If you find that you cannot stay within these guidelines, you must seek approval from Show Management. For consideration, please contact Dennis Miller at 780.690.2600.

ENGINEERING CERTIFICATION

Booth structures such as towers and columns that exceed 12' (3.66 m) in height (excluding hanging signs), or are two story Exhibits (any height), regardless of whether people will occupy the area or not, will require engineering certification verifying structural integrity of the Exhibit. Acceptable Certification is in the form of a Certified Structural Engineer's stamp or seal from the Province of Alberta directly on your set of blueprints for the Exhibit.

This Certification must be submitted to Show Management 3 weeks prior to move-in. Failure to obtain and submit the required documentation could delay or prevent construction of your Exhibit. Signs must be posted indicating the number of people the structure will accommodate. This policy has been established to ensure the safety of Exhibitors and Attendees at the Show.

STRUCTURAL INTEGRITY

All exhibit fixtures, especially portable or "pop-up" Booths, must be erected in a manner to withstand normal contact or vibration due to outside forces such as wind, the movement of forklifts, heavy machinery, or equipment, and unintentional contact on the part of cleaners, labourers, or neighbouring Exhibitors.

SIGHT LINES

All Exhibitors are equal regardless of size and should be given equal opportunity, within reason, to present their product in the most effective manner to the audience. Therefore, all Exhibitors shall abide by sight line guidelines to ensure their neighbours visibility from the aisle, and vice versa. With the advent of standalone popup banners, we see many examples of interference of sight lines. This will not be tolerated. Show management will visit each booth to check sight lines.

BOOTH CONFIGURATIONS GUIDELINES

STANDARD OR IN-LINE AND PERIMETER BOOTHS

One or more 10' x 10' units in a straight line. Perimeter booth backs to a wall of exhibit facility rather than another exhibit. Maximum back wall height permitted is 8 feet that may extend out 4 feet from the back wall of the booth; maximum side wing divider height is 4 feet.

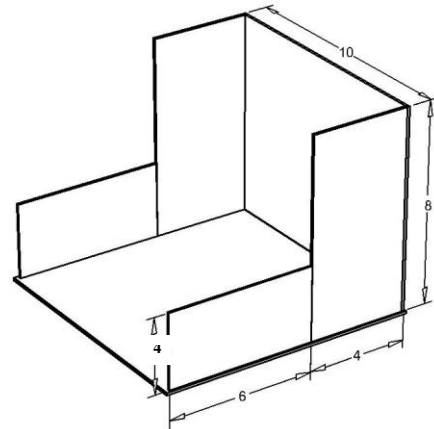
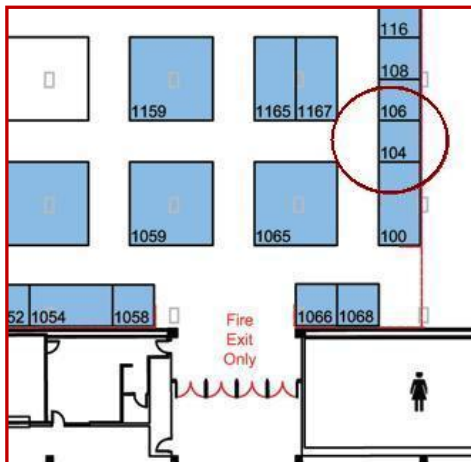

END-CAP BOOTH

10' x 20' exhibit space exposed to aisles on three sides. Maximum back wall height in the rear half of the booth space, and if possible, within 5 feet of the two side aisles with a 4-foot height restriction imposed on all materials in the remaining space forward to the aisle.

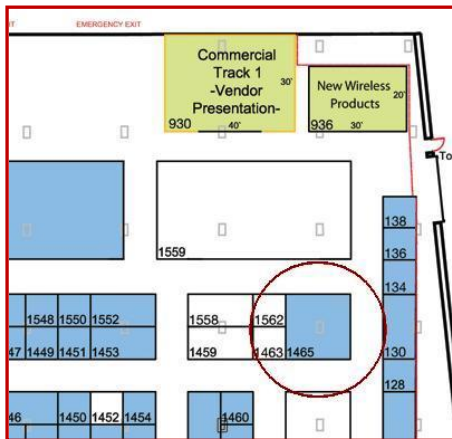
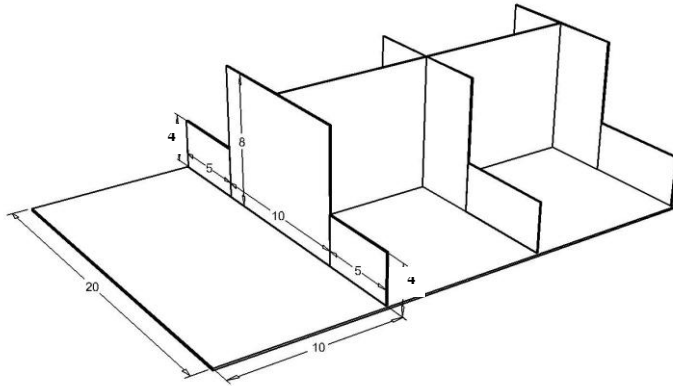

PENINSULA BOOTH

20' x 20' or larger exhibit space exposed to the aisle on three sides. There are two types of peninsula booths:

PENINSULA ABUTTING STANDARD OR IN-LINE BOOTH

When a peninsula backs up to two standard or in-line booths, the back wall is restricted to 4 feet high, and if possible within 5 feet of each aisle (permitting adequate line of sight for the adjoining standard booths). The remaining back wall height restriction is 16 feet, including signage for the centre portion of the back wall. The backside of the wall must be finished and not contain signage or logos.

PENINSULA ABUTTING PENINSULA

When a peninsula backs up to another peninsula booth, the back wall is restricted to 16 feet high. The backside of the wall must be finished and not contain signage or logos.

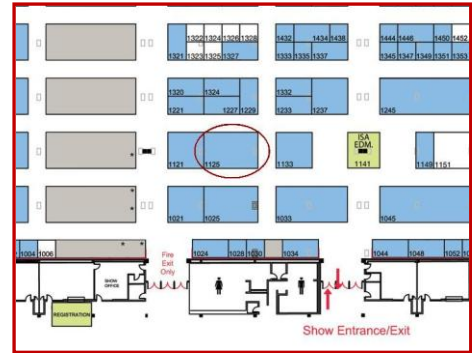
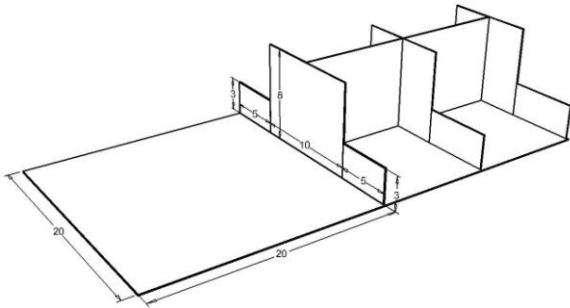

ISLAND BOOTH

A block of exhibit space with aisles on all four sides. Maximum height permitted is 16 feet, which if required, must be located in the internal portion of the booth and not exceed 10 feet width in any direction. Perimeter walls regardless of height are not permitted in island booths.

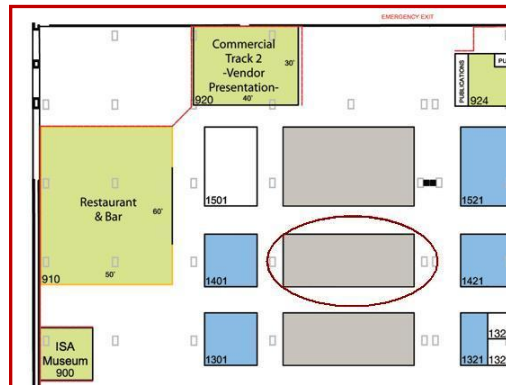

2.15 SIGNS

Signs must be professionally designed and constructed, lightweight and in good taste. Your signs must not constitute a danger to visitors or infringe on other exhibitors. The top of any sign may not exceed 16 feet above the floor level. The sign must be located at least 3 feet from the perimeter of the booth, which are 3 feet from the neighbouring booth and 3 feet back from the front boundary of the booth.

When a sign is placed over the 8-foot level of the booth wall and is visible to those viewing booths in the aisle behind it, the rear of the sign must be covered or finished in such a manner as to not detract from those booths behind it. Signs may be suspended over your booth area, making sure to follow the above requirements. The Electrical Contractor listed in Section 5.0 – Showtech Power & Lighting, must handle the hanging of signs

Under no circumstances may banners, decorations, or signs and similar material be nailed, stapled, screwed, taped, or attached to ceilings, walls, or other painted surfaces without prior written approval of the method of installation by the building management. Helium balloons and glitter require prior authorization for use within your booth.

2.16 FIRE REGULATIONS

The following fire and safety regulations must be adhered to governing exhibits and displays:

1. Decorating materials, including: artificial flowers and foliage, shall be inherently flameproof or properly treated with a flame retardant.
2. Unless otherwise approved, flammable or combustible and/or compressed gases shall not be used or displayed.
3. ***AEROSOLS - It is permitted to exhibit one pressurized container; not exceeding one-pint capacity of each product classified as flammable liquid.***
4. Motor vehicles or gasoline-powered equipment on display shall be restricted to $\frac{1}{4}$ of a tank of fuel and be equipped with a lock-on type gasoline cap. Batteries need NOT be disconnected. Keys must be removed from all vehicles.
5. All storage shall be kept in allocated areas. No empty cardboard containers are permitted to be stored in the booth space.
6. Cylinders containing compressed gases shall be protected against mechanical damage and shall be stored on racks or by other accepted devices designated to hold them securely in place.
7. A propane-fueled vehicle may be parked indoors, provided there are no leaks in the propane system and the tank is not filled beyond its maximum permitted density.
8. A propane-fueled vehicle, while indoors, shall have the shut-off valve closed and secured to prevent tampering.
9. A propane-fueled vehicle, while indoors, shall not be parked near a source of heat, open flame, or any source of ignition, or near an open pit or drain.
10. No propane cylinders are permitted in any indoor exhibits.

2.17 SMOKING BY-LAW

In accordance with the City of Edmonton By-Law, the **NO SMOKING** policy will be strictly enforced in all buildings. Smoking will be permitted **OUTSIDE** only in designated smoking areas.

2.18 CUSTOMS BROKER/FREIGHT CARRIER/ADVANCE RECEIVING

RE Rogers is the official Customs Broker and Freight Carrier for the ISA Edmonton 2012 Exhibit and Conference. For exhibition material being shipped from outside Canada, this company will assist you with customs clearance of all shipments and coordinating delivery to the Show site. At, or prior to the end of the show, RE Rogers will prepare all required documentation for export of your goods, clearance by Canada Customs, and US Customs at port of entry. They must be notified if you require clearance by a specific US Customs Broker. Consumption entries will be made for any goods imported on Temporary Entries that are remaining in Canada. The exhibitor is liable for any duty and GST payable. An information sheet on customs Brokerage and an order form for "Canada Bound" shipments are available ...log in to the **Exhibitor Resources** by clicking the [Secure Exhibitor Login](#) at <http://isaedmontonshow.ca/>

Make out the bill of lading and consign as follows.

Shipment will be received at the following address beginning March 16 to April 16.

Name of Exhibiting Company
ISA EDMONTON 2012
Booth Number _____
R.E. Rogers Canada Inc.
C/O Derrick Exhibit
7710 34th Street
Edmonton, Alberta
Canada T6B 3J6

ALL SHIPMENTS MUST BE SENT PREPAID! COLLECT OR C.O.D. SHIPMENTS WILL BE REFUSED AT THE SHOW SITE. ANY FREIGHT THAT IS SENT DIRECTLY TO THE SHOW SITE MUST NOT ARRIVE PRIOR TO APRIL 16, 2012. IF THE SHIPMENT ARRIVES PRIOR TO THIS DATE IT WILL BE REFUSED AND SENT BACK TO THE CONSIGNEE AT THEIR COST.

Documentation downloads are available...log in to the Exhibitor Resources by clicking the [Secure Exhibitor Login](#) at <http://isaedmontonshow.ca/>

2.19 FREIGHT CARRIER/ADVANCE RECEIVING

R.E. Rogers Canada Inc. is the official Freight Carrier offering a special service for exhibitors participating in the ISA Edmonton 2012 Exhibit and Conference.

R.E. Rogers Canada Inc. or one of their agents (A list of worldwide agents is available...log in to the **Exhibitor Resources** by clicking the [Secure Exhibitor Login](http://isaedmontonshow.ca/) at <http://isaedmontonshow.ca/>) can arrange pick up from your door to deliver to show site and return to your door. For a quotation, please complete the Cost Estimate sheet available at www.isaedmontonshow.ca.

For those exhibitors who utilize R.E. Rogers Canada Inc. on direct inbound moves to the show, R.E. Rogers Canada Inc. will provide up to 30 days free storage prior to move-in.

MARKING

All shipments direct to show site must be consigned and labeled as follows:

Name of Exhibiting Company
ISA EDMONTON 2012
Booth Number _____
Edmonton Expo Centre
Edmonton, Alberta, Canada

For International or transborder shipments notify on arrival: R.E. Rogers Canada Inc. –
Tel: 403-291-0360 Fax: 403-291-0397

All inbound shipments consigned to ISA Edmonton 2012 must move with complete third party billing instructions or as a prepaid shipment, as neither the materials handlers nor the exhibit facility will accept collect shipments.

To receive a free quotation, please complete the attached cost estimate sheet and either fax it or email it to R.E. Rogers Canada Inc at 403-291-0397 or abennett@rerogers-canada.com

Documentation downloads are available...log in to the **Exhibitor Resources** by clicking the [Secure Exhibitor Login](http://isaedmontonshow.ca/) at <http://isaedmontonshow.ca/>

2.20 OUTBOUND SHIPPING AND HANDLING

Each exhibitor will be expected to label exhibit materials and to supply outbound shipping information. Labels and Bills of Lading will be available at the official carrier's service desk or from your selected carriers. Previous shipping labels must be removed or obliterated, as Show Services accepts no responsibility for misdirected shipments due to old shipping labels.

2.21 REMOVAL OF EXHIBITOR MATERIAL

All exhibitor material must be removed from the building by:

THURSDAY, APRIL 19, 2012 5:15 P.M. – MIDNIGHT

Exhibitor material that is not cleared from the building by this time will be removed at the expense of the exhibitor. If forced removal of exhibitor material is required, Superior Show Service will remove the materials. The material will then be delivered to the loading docks where it will be loaded onto Superior Show Service's trucks. These goods will then be delivered to Superior Show Service's warehouse and the exhibitor will be contacted to make the necessary arrangements for delivery or pickup.

2.22 SHOW CONTRACTOR

Superior Show Service is the official Show Decorator responsible for the following:

- Booth Cleaning
- Carpet
- Exhibit System Rentals
- Furniture and Accessories
- Graphics and Signage
- Installation/Dismantling
- Materials Handling
- On-Site Forklift Handling
- Plants and Foliage
- TV's and DVD Players

Order forms for Superior Show Service available online...log in to the **Exhibitor Resources** by clicking the [Secure Exhibitor Login](http://isaedmontonshow.ca/SecureExhibitorLogin) at <http://isaedmontonshow.ca/>

Essential Information

All in-line booths will be provided with pipe and drape.

- Backwall height 8 feet
- Sidewall height 4 feet

The backwall and sidewall divider drapes are black and silver in colour and are flame proof. The aisle carpet is red in colour.

2.23 JANITORIAL SERVICE

Aisle and common areas will be vacuumed each day prior to the show opening. Exhibitors are responsible for keeping their booth space clean and tidy at all times. Booth cleaning services are available from Superior Show Services Inc. by completing the booth cleaning order form enclosed.

2.24 LEAD RETRIEVAL

Show Management provides delegates with bar-coded badges. These badges can be scanned with a barcode scanner that is available to all exhibitors on a rental basis from CONEXSYS. Use of a scanner will significantly speed up the process of lead capture and retrieval. For details, PDF downloads are available...log in to the **Exhibitor Resources** by clicking the [Secure Exhibitor Login](http://isaedmontonshow.ca/SecureExhibitorLogin) at <http://isaedmontonshow.ca/>

3.0 OFFICIAL SHOW CONTRACTORS

<p>OFFICIAL SHOW CONTRACTOR</p> <p>SUPERIOR SHOW SERVICE INC. 8599 - 111 Street Fort Saskatchewan, Alberta T8L 4S1 Canada</p> <p>Contact: Tom Siever</p> <p>Toll Free: 1.888.417.4449 Fax: 780.992.0406</p> <p>E-mail: tom@superiorshow.com Website: www.superiorshow.com</p>	<p>OFFICIAL ELECTRICAL/LIGHTING SUPPLIER</p> <p>SHOWTECH POWER & LIGHTING 9797 Jasper Avenue Edmonton, AB T5J 1N9 Canada</p> <p>Contact: Debbie Buerger</p> <p>Phone: 780.429.1162 Fax: 780.424.4715</p> <p>E-mail: dbuerger@showtech.ca Website: www.showtech.ca</p>
<p>OFFICIAL CUSTOMS BROKER & FREIGHT CARRIER</p> <p>R.E. ROGERS CANADA INC. 71 Bermuda Place NW Calgary, Alberta T3K 1H4 Canada</p> <p>Contact: Andrew Bennett</p> <p>Phone: 403.291.0360 Fax: 403.291.0397</p> <p>E-mail: abennett@rerogers-canada.com Website: www.rogers-canada.com</p>	<p>OFFICIAL LEAD RETRIEVAL SUPPLIER</p> <p>CONEXSYS Unit 9, 6115 – 4 Street SE Calgary, AB T2H 2H9 Canada</p> <p>Contact: Barry Cassidy</p> <p>Toll Free: 888.400.9499 Fax: 403.254.0472</p> <p>E-mail: barry@conexsys.ca Website: www.conexsys.ca</p>

* Additional Information & Forms are available...log in to the [Secure Exhibitor Login](#) using the username & password that was sent to you via email. If you have not received an email with this pertinent information, please contact Dennis Miller at info@isaedmontonshow.ca

4.0 ISA EDMONTON 2012 EXHIBIT & CONFERENCE PRIMARY CONTACTS

Please feel free to contact any of these exhibit and conference committee members for more information:

EVENT COORDINATOR

CEM Charlton Event Management

126, 150 Chippewa Road
Sherwood Park, AB T8A 6A2
Canada

Contact: Dennis Miller

Phone: 780.690-2600

Fax: 780.449.3529

Email: info@isaedmontonshow.ca

OFFICIAL EVENT GUIDE PUBLISHER

Execu Graphx Inc.

126, 150 Chippewa Road
Sherwood Park, AB T8A 6A2
Canada

Contact: Marietta Miller or Lea-ann Gerling

Phone: 780.467.6729

Fax: 780.449.3529

Email: info@execugraphx.com

EXHIBIT AND CONFERENCE DIRECTOR

James Dickie
Edmonton Valve and Fitting

Phone: 780.437.0640

Fax: 780.435.6935

E-mail: james.dickie@edmontonvalve.com

ISA EDMONTON SECTION PRESIDENT

Ian Verhappen
Industrial Automation Networks

Phone: 780.668.0479

E-mail: iverhappen@industrialautomationnetworks.com

EXHIBIT AND CONFERENCE MAILING ADDRESS

P.O. Box 92123
Meadowbrook RPO
Edmonton, AB T6T 1N1